

## THERMOSTATS SERIES TH 220, TH 221

### Descriptions

TH 220 series thermostats are temperature dependent single pole switches, working on the principle of unequal thermal dilation of their different metals. The temperature sensitive element is the stem of the thermostat, made of a brass tube. The control knob for setting the desired temperature can be locked to prevent, for example, the switching temperature from being reset due to shocks. The thermostats are manufactured in a switching (three-clamp) design with a protective earth terminal on the cover.

### Dimensional drawings

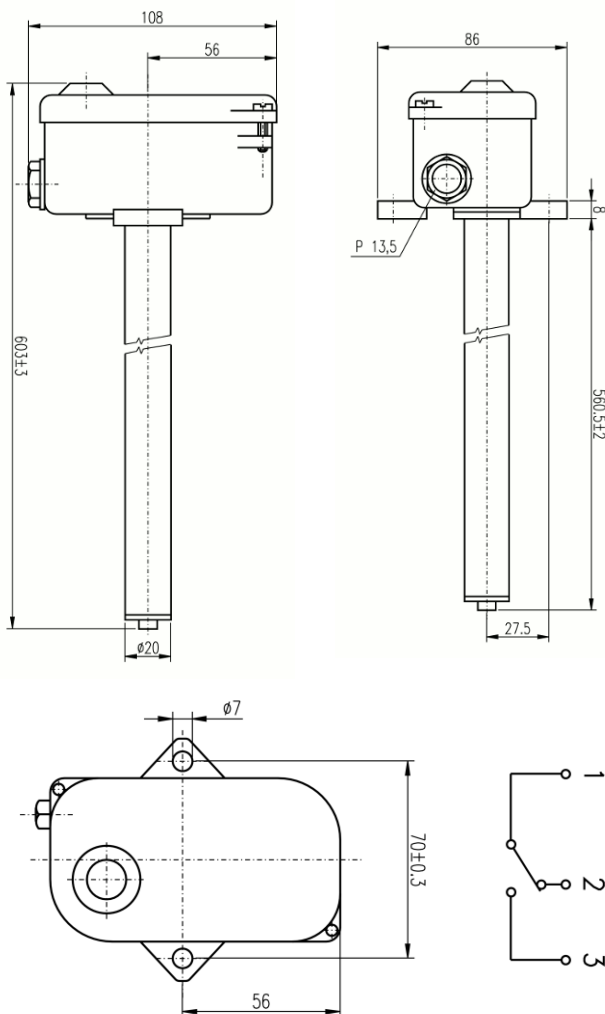

### Installation

Installation and connection of the thermostat to the electrical circuit may only be carried out by a person qualified according to Decree no. 50/1978 min. §6 or by a professional service worker. The following recommendations must be followed during installation:

- The thermostat is equipped with a ground terminal and must be grounded with a protective conductor
- The thermostat must be installed in such a way that it is not damaged during installation or adapted to the installation conditions. Particular care must be

taken to ensure that the thermostat stem is not bent or dislodged from the base plate

- Installation is done with two screws behind the feet on the thermostat head
- Thermostats must be installed in AB7, AE3, AM1, AB1, BE1 environments that are free of fumes or gases of chemicals that may damage thermostat parts
- Thermostat switch is designed for electrical circuit with ohmic load up to min. power factor value 0.95
- Conductors to be fitted with pressed brass sleeves according to ČSN 37 1366

### Intended usage

Thermostats are used to switch electrical circuits, but not as the main switch. The TH 220 thermostat is designed for DC loads and therefore the switching contacts are bridged with quench capacitors. TH 221 thermostats are designed for AC voltage. The stem must not be mechanically stressed during installation and must be positioned so that it can expand freely. The thermostats are designed to control the temperature in these devices:

- TH 220, 221 for temperature control with air conditioners

Other uses must be consulted with the manufacturer. To install the TH, follow the instructions in the manual of the device in which the TH is installed

### Effect on other products

As a result of the operation of the TH, there is a short-term voltage fluctuation at the contacts, which is superposed to the power supply wave shape.

### Technical data

<b>Control range</b>	-20÷60°C
<b>Rated sensitivity</b>	1÷3°C
<b>Settings accuracy</b>	±5% from control range
<b>Weight</b>	800 g
<b>Impact resistance</b>	5g, 1÷2 c/s
<b>Ingress protection of the head</b>	IP 44
<b>Contacts</b>	switching
<b>Permissible temperature of the stem</b>	-30÷140°C
<b>Permissible temperature of the head</b>	0÷120°C
<b>Contact load</b>	
TH 220	60 V, 1 A=; 120 V, 0,5 A=
TH 221	250 V, 15 A~

## Storage conditions

Storage can be done in closed ventilated areas in the temperature range 0-40°C with a maximum relative humidity 80%. Storage and handling must not cause mechanical damage to the instrument. The thermostats must be handled gently, without strong shocks and impacts.

## Disposal

Dispose of TH as follows: Take the TH to a scrap yard

## Possible minor faults and their removal

The thermostat may be repaired only by the manufacturer

## Warranty

Provided that the thermostat is installed, wired and used in accordance with the instructions in the installation and operating instructions, the manufacturer warrants the thermostat in accordance with the applicable code, unless otherwise agreed.

The manufacturer will refuse warranty repairs of the unit has been damaged:

- During transport and storage by the customer or his customers
- During installation or dismantling on the equipment of the customer or his customers
- In case of improper handling an installation in equipment other than that is specified in the instructions
- If the thermostat has been exposed to an environment other than specified in the instructions

## Warranty and post-warranty repairs

Warranty and post-warranty repairs are provided by the manufacturer. Pack the defective product and send it to following address:

### APATOR POWOGAZ CZECHIA s.r.o.

Havlíčková 919/24

787 01 Šumperk

Czech Republic

Tel.: 583 718 261

E-mail: [prodej@metra-su.cz](mailto:prodej@metra-su.cz)

www: [www.metra-su.cz](http://www.metra-su.cz)